

INSTALLATION INSTRUCTIONS

RECESSED DOWNLIGHT & WALL WASH FIXTURES: 2000LM-LED MODULE

B3-ALT HOUSING

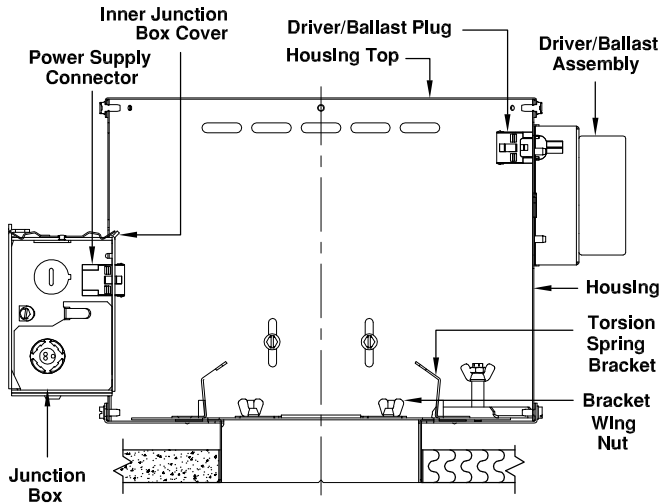

Fig. 1

← approx. 1/4" both directions
(left to right / forward and backward)

Note: If required:

Before ceiling is closed, loosening two wing nuts, at corner of housing, (not bracket wing nuts) allows square aperture to be aligned with other fixtures in fixture pattern. Re-tighten wing nuts when desired alignment is attained.

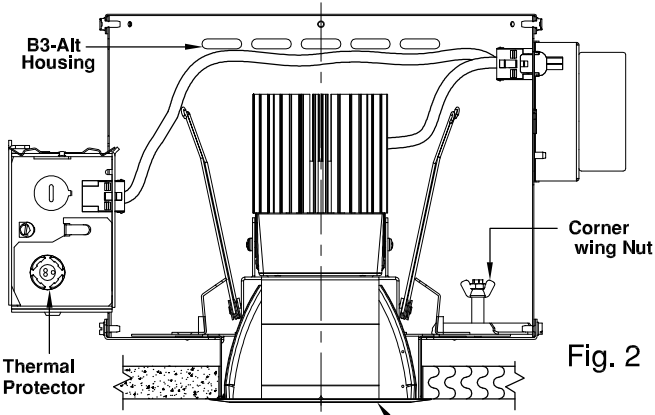
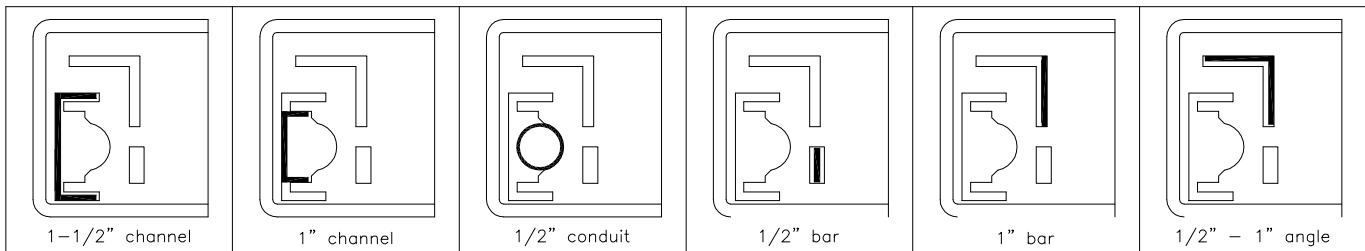

Fig. 2

Rail Supports

Fig.3

Trim Assembly
(See Trim Options)



Supports accept many types of rails. Job site scrap may be used.

KV3508 Union made IBEW.

Notes

- 1 Make sure power is off. Building wires must be in compliance with local codes.
- 2 All Electrical Wiring Must Be Made by a Licensed Electrician.
- 3 Rails are not supplied unless ordered. They come in two sizes 26" and 52". Contact the factory. Available immediately.
- 4 Fixture must be above ceiling before closing in.

Installation

- 1 Remove the trim assembly. Use the aperture frame as a template to mark the tile for the aperture hole.
- 2 Cut tile aperture opening for snug fit around the aperture frame.
- 3 Fasten rail supports to internal adjustment brackets on housing. Insert rails by gently squeezing wings of rail supports together to ease passage of rails. Do not squeeze too hard or the rail supports will take a set. When pressure is released, the rail support will lock onto rails. (See Fig. 3 & 5)
- 4 Remove proper knockouts from junction box and attach connectors.
- 5 Place fixture in tile hole. Tie the rails loosely to support members of the ceiling grid.
- 6 Adjust fixture so aperture frame is flush with finished tile face or 1/16" above. Do not allow aperture frame edge below tile face or more than 1/16" above. Tighten rails to ceiling grid permanently. (See Fig. 5)

Wiring

- 1 Attach conduit or flex to junction box. Make all splices.
- 2 Fixture must be grounded with green screw or grounding wire provided.

Installation of LED Module Trim Assembly (See Fig. 4)

- 1 Push in LED wire plug into two pin plug in driver plate.
- 2 Squeeze torsion spring and engage into slot of torsion spring bracket.
- 3 Push trim up into fixture until trim flange is flush with ceiling.

Access to Junction Box: (See Fig. 1)

Remove trim, release wire plug, remove inner junction box cover

Quality Control

Every effort is made to assure that our products reach the job in perfect condition. We welcome your comments.

Kurt Versen Company may change construction periodically without notice as part of its program for product improvement.

Warning

Risk of fire. Do not install insulation within three inches of the fixture sides or top in such a manner as to entrap heat.

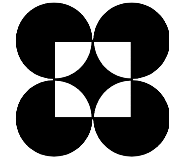

INSTALLATION INSTRUCTIONS

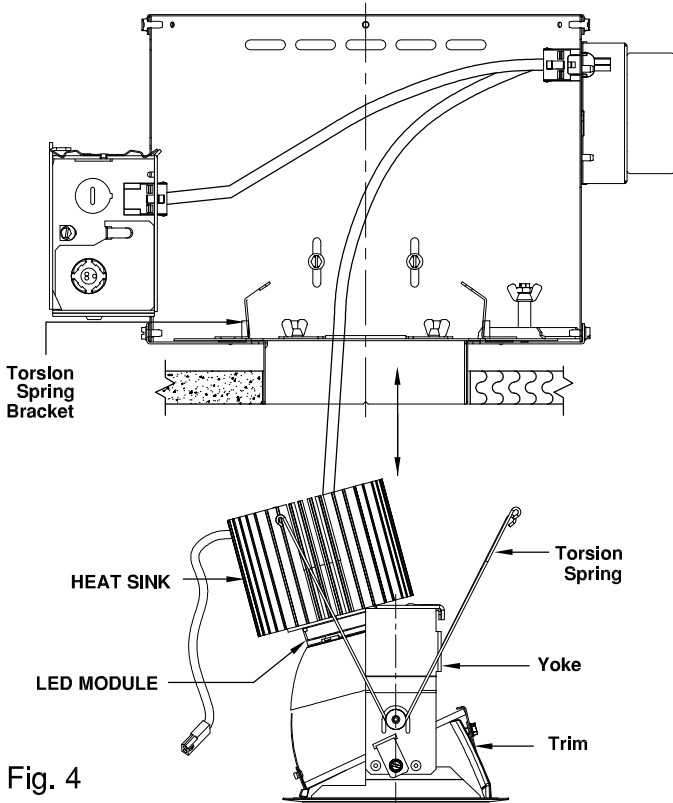

Fig. 4

CORRECTIVE ADJUSTMENT (Fig. 5)

(AFTER INITIAL INSTALLATION)

- A Remove cone.
- B Loosen all 4 screws. (2 on each end)
- C To move fixture up, push up against the housing top.
- D To move fixture down, pull down on the aperture pan.
- E Once in the correct position, tighten all 4 screws.
- F Reinstall cone.

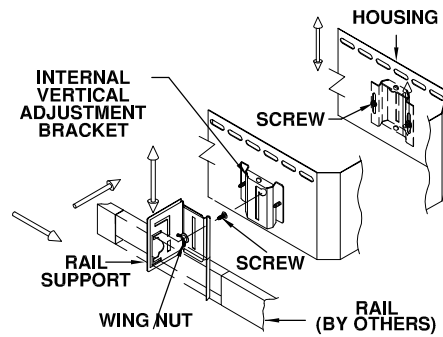
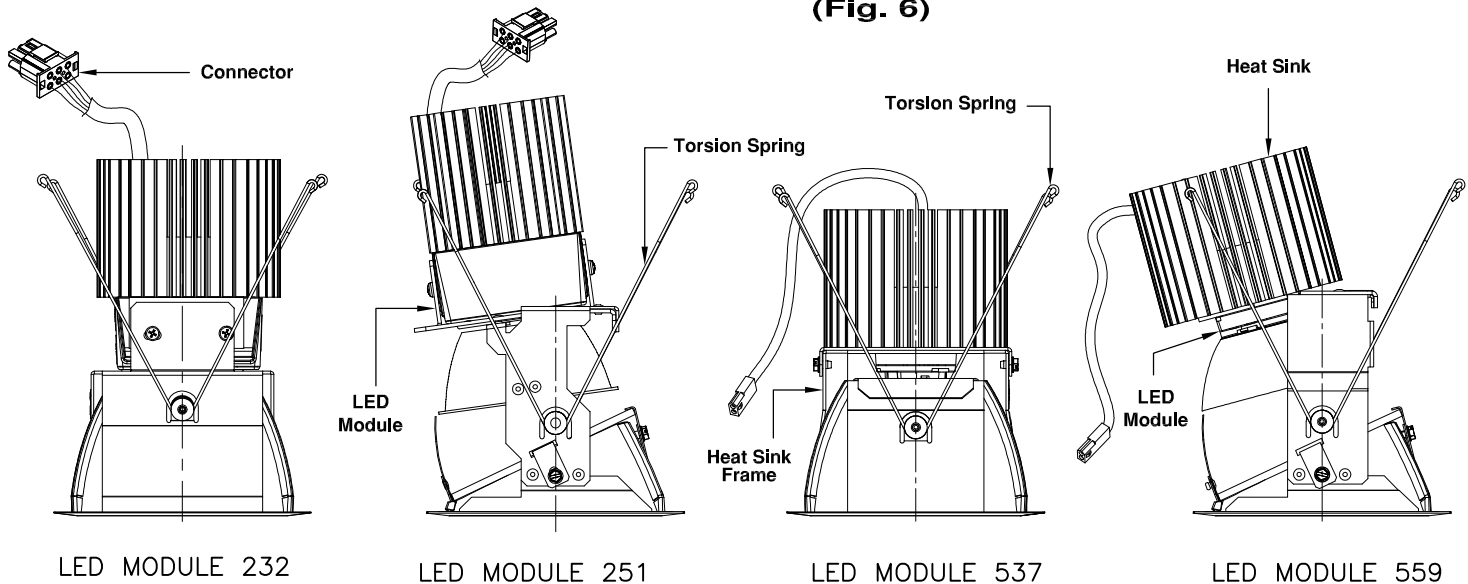

Fig. 5

CAUTION: TURN POWER OFF, BEFORE RELAMPING OR REPLACING ANY LAMP

TRIM OPTIONS: 232, 251, 537, & 559

(Fig. 6)



LED MODULE 232

LED MODULE 251

LED MODULE 537

LED MODULE 559

Fig. 6